

**MANHOLE INLET/OUTLET DETAIL**

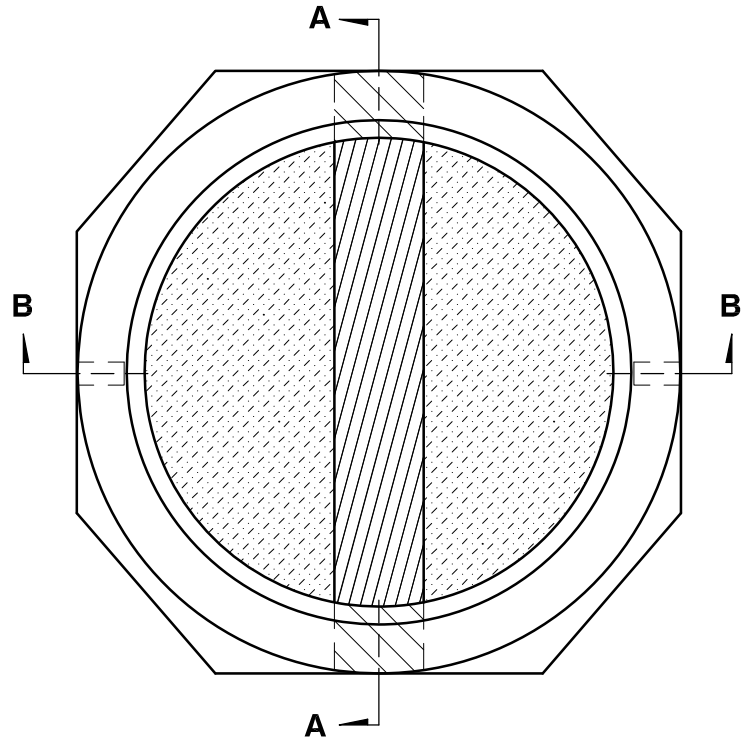

**PLAN VIEW**

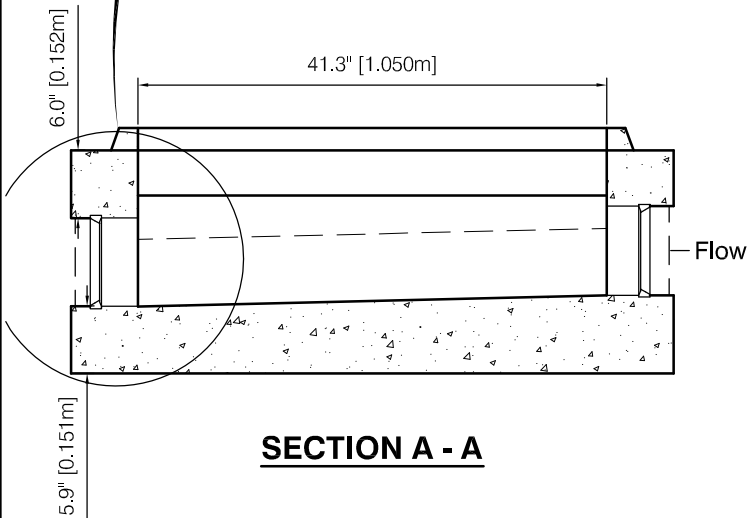

**SECTION A - A**

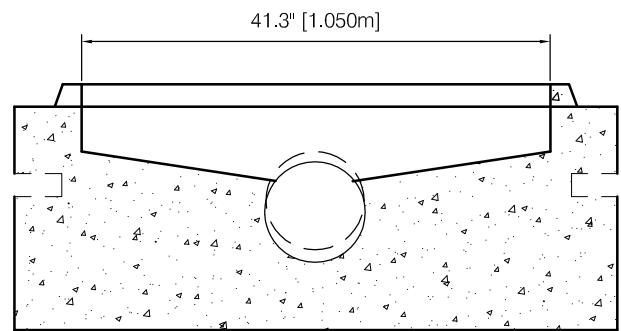

**SECTION B - B**

**Notes:**

1. Manufactured to ASTM C478, C923M Specs.
2. Min. concrete strength: 35 MPa.
3. Reinforcing in walls and bottom slab.
4. Min. 150mm wall on base section.
5. Min. 150mm thickness below pipe invert.
6. All benching has metal trowel finish.
7. Min. 25 mm fall carried through base.
8. All dimensions in millimeters.



A Subsidiary of Northern Vac Services Ltd.  
 P.O. Box 6868  
 Fort St. John, B.C., V1J-4J3  
 Phone: (250) 785-3382  
 Fax: (250) 785-3381  
 Email: nvac@shaw.ca

**STANDARD PRE-BENCH  
 MANHOLE BASE**

Drawn:	DVT	Cert #	---	Dwg No.	---
Date:	December 2015			Rev:	0



A Division of Northern Vac Services Ltd.  
 4665 Collier Place  
 Williams Lake, B.C., V2G-5E0  
 Phone: (250) 392-3169  
 Fax: (250) 392-3176  
 Web: www.grossoprecast.com