

# MODEL # STK-0240-1C

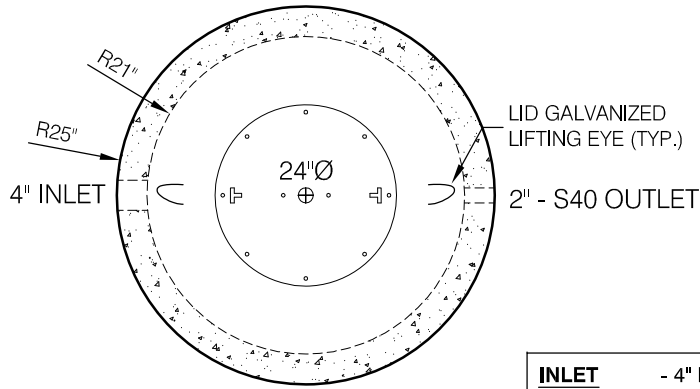

**TOP VIEW**

**INLET** - 4" POLY TANK BOOT  
REDUCED TO 3" + 2".  
**OUTLET** - 2" RUBBER BOOT

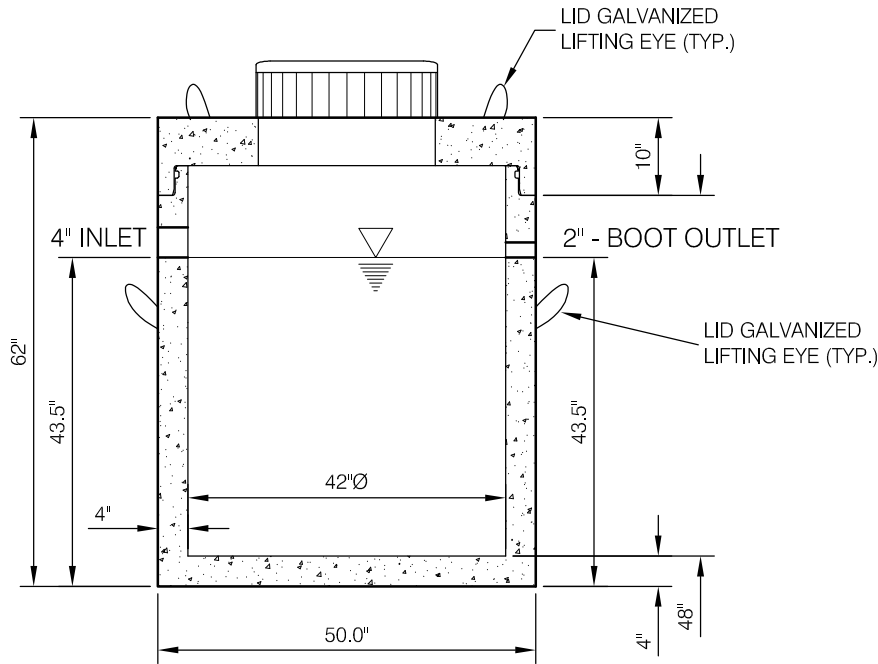

**SECTION VIEW**

## Design Data

1st COMP - 240 Imp Gal  
TOTAL VOLUME - 240 Imp Gal  
GASKET - 1" Conseal  
1 - 24" PVC LID AND RISER

## Concrete Strength

30mpa @ 28 days.  
USE IN SULPHATE & NON  
SULPHATE SOILS.

## Dimensions

DIAMETER: 42" INSIDE  
HEIGHT: 62"  
INLET: 40"  
OUTLET: 43.5"



A Subsidiary of Northern Vac Services Ltd.

P.O. Box 6868  
Fort St. John, B.C., V1J-4J3  
Phone: (250) 785-3382  
Fax: (250) 785-3381  
Email: nvac@shaw.ca



A Division of Northern Vac Services Ltd.

4665 Collier Place  
Williams Lake, B.C., V2G-5E0  
Phone: (250) 392-3169  
Fax: (250) 392-3176  
Web: www.grossoconcrete.com

**240-GAL (1089 litres)  
1-COMP PUMP CHAMBER  
LID 1,000 lbs: BARREL 3,700 lbs:  
TOTAL 5,000 lbs**

Drawn: DVT	Checked by: CL	Dwg No. 101
Date: February 15 / 2012	Cert # —	Rev: 1