

ITEM No. 913
CTB-3

2800 lbs

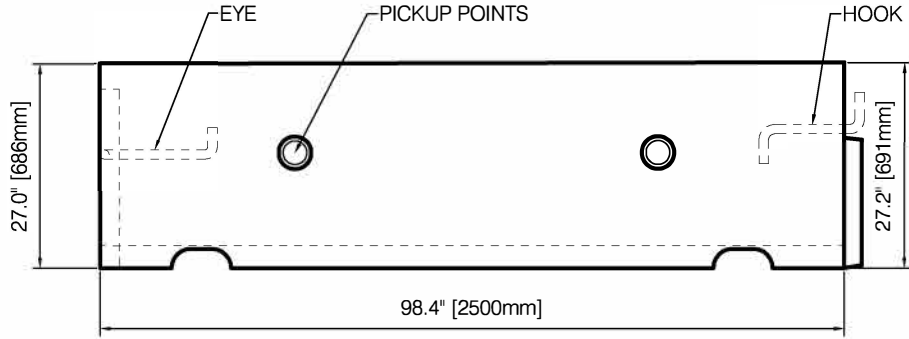

ITEM No. 914
CTB-1

2417 lbs

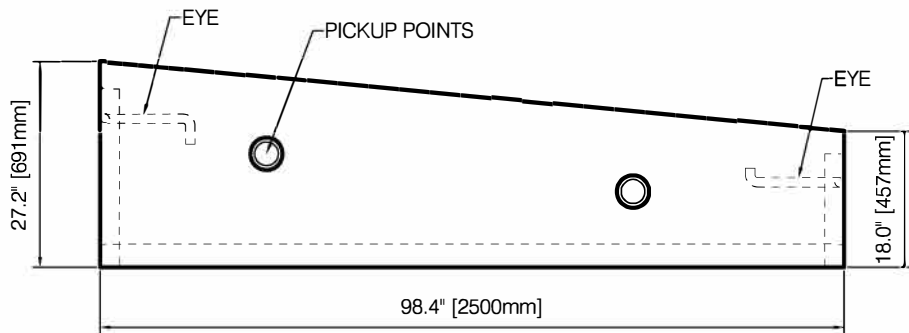

ITEM No. 916
CTB-2

1783 lbs

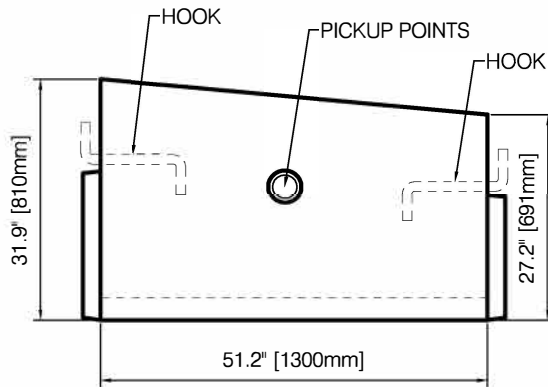

Concrete Strength

32 MPa @ 28 days.
MANUFACTURED AS PER MOT SECTION 941



A Subsidiary of Northern Vac Services Ltd.

P.O. Box 6868
Fort St. John, B.C., V1J-4J3
Phone: (250) 785-3382
Fax: (250) 785-3381
Email: nvac@shaw.ca

CONCRETE TRANSITION BARRIERS
ITEMS No. 913, 914 & 916

Drawn: DVT	Checked by: CL	Dwg No. ---
Date: February 2016	Cert # ---	Rev: 0



A Division of Northern Vac Services Ltd.

4665 Collier Place
Williams Lake, B.C., V2G-5E0
Phone: (250) 392-3169
Fax: (250) 392-3176
Web: www.grossoconcrete.com