

SECTION VIEW

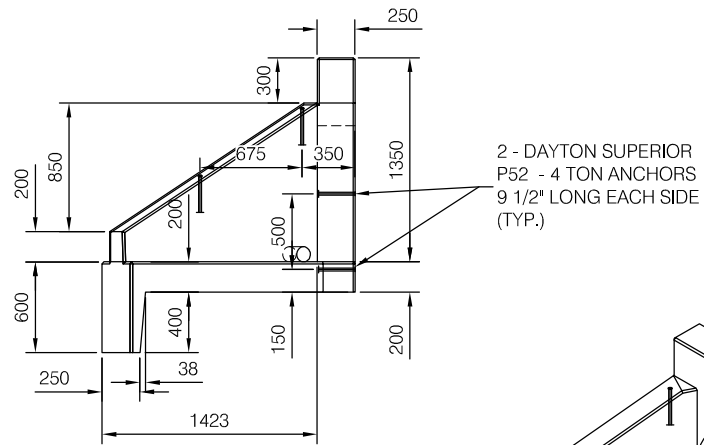

SIDE VIEW

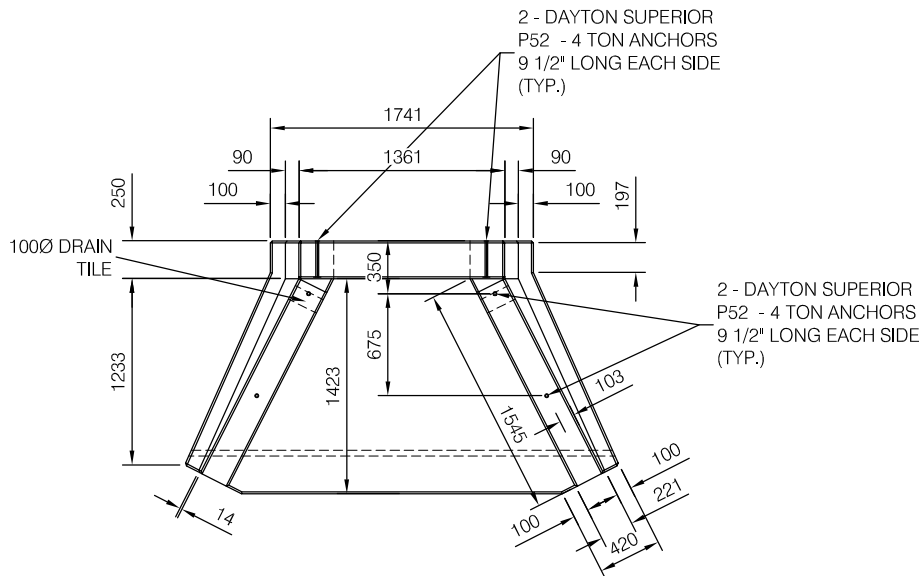
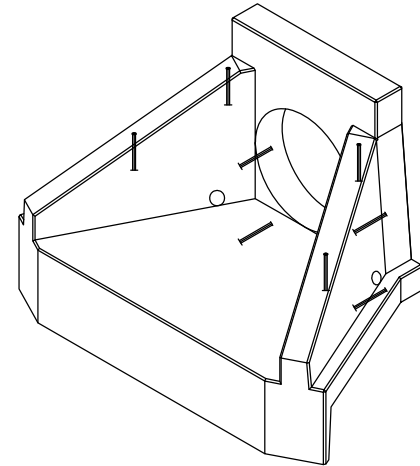

TOP VIEW

NOTE:
 8 - DAYTON SUPERIOR
 P52 - 4 TON ANCHORS
 9 1/2" LONG REQUIRED (TYP.)

Concrete Strength

- 32mpa @ 28 days
- Exposure class S-2
- 1/2" chamfer on all exposed edges
- 14,000lbs (6,350kg) ~2.6cu/m
- 21 Mpa @ stripping



P.O. Box 6868
 Fort St. John, B.C., V1J-4J3
 Phone: (250) 785-3382
 Fax: (250) 785-3381
 Email: www.wilsonconcrete.ca

4665 Collier Place
 Williams Lake, B.C., V2G-5E0
 Phone: (250) 392-3169
 Fax: (250) 392-3176
 Web: www.grossoprecast.com

MOTI SP303-01
CONCRETE HEADWALL
2120mm x 1350mm TALL

| | | | | | |
|--------|---------------|-------------|---------|---------|---|
| Drawn: | DVT | Checked by: | AD / CL | Dwg No. | |
| Date: | May 12 / 2023 | Cert # | | Rev: | 3 |